

NEW! Wi-Fi® & Wi-Fi + Bluetooth® Combination Short-Range Radio Modules



Best-in-Class Combination Short-Range Radios from RFM

Like all RFM's integrated short-range range products, the WLS Series of Wi-Fi and Wi-Fi + Bluetooth combination modules are optimized for RF performance and feature a high-level of integration all in a small form factor. The benefits to designers are low-cost, efficient design cycles, and fast time-to-market.

The WLS-Series of products include Wi-Fi and Bluetooth technology in a single SoC and a high-efficiency RF front-end circuit plus a DC-DC converter. The modules are designed to fit into small spaces and are slightly smaller than a US dime. Minimal external circuitry is required to complete a radio design; add an antenna, power source, processor, and associated interface hardware and the radio hardware design is complete.

Audio / Video / Data

Low Cost

Small Form Factor



Standards-Based Connectivity

Immediate access to information and ease of connectivity are the key drivers for Wi-Fi and Bluetooth becoming the communications protocol standards world-wide.

As a result, the RFM WLS-Series short-range radio modules are ideal for original equipment manufacturers (OEMs) wanting to quickly add Wi-Fi and / or Bluetooth connectivity within a broad range of products for the world-wide marketplace.

- Medical / Healthcare
- Asset Tracking / RFID
- Consumer Products
- Military / Homeland Security
- Smart Energy – AMI / AMR
- Set-top Boxes
- Industrial Control
- Handheld Devices
- Gaming Devices

WI-FI & WI-FI + BLUETOOTH COMBINATION SHORT-RANGE RADIO MODULES

WLS1270 2.4 GHz

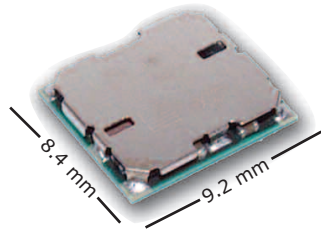

Wi-Fi Compliant Only

WLS1271L 2.4 GHz

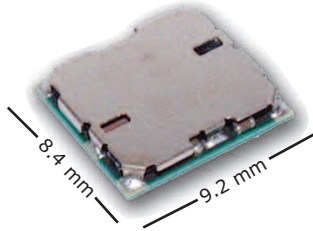

Wi-Fi and Bluetooth Compliant + Bluetooth Low Energy

WLS1273L 2.4 GHz & 5.8 GHz

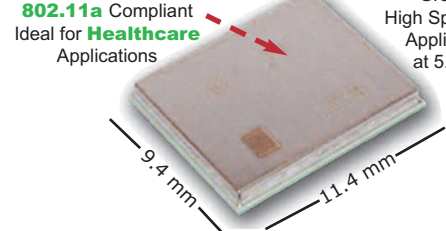

RFM WLS-Series Short-Range Radio Modules provide a solution that is design-optimized for high RF performance and to be size-efficient. These products are manufactured in an automated, high volume environment to provide a high-quality, low-cost solution.

The WLS-Series modules represent best-in-class WLAN and Bluetooth coexistence technology on a single-chip and include high-efficiency RF front-end circuits plus a DC-DC converter. The module is designed to fit into small spaces, with minimal external circuitry required to complete a radio design. These attributes result in a solution that is cost-effective and reduces the product design cycle.

Wi-Fi and Bluetooth Compliant. To ease Wi-Fi and Bluetooth certifications, all three modules comply with IEEE 802.11b/g/n and WLS1273L complies with 11a, while the WLS1271L and WLS1273L modules comply with Bluetooth Version 4.0 plus EDR, Power Class 1.5 + BLE.

FCC / ETSI Certifiable. Like all RFM Short-Range Radio products, the WLS-Series Modules are FCC and / or ETSI certifiable.

WLS-Series products are shipped in tape and reel with standard order increment of 1,000 on 13" reels.

WLS-Series Wi-Fi / Bluetooth Combo Short-Range Radio Module					
RFM Part	Frequency	IEEE 802.11	Bluetooth	Description	Case
WLS1270	2.412-2.485 GHz	b/g/n compliant	n/a	802.11b/g/n Short-Range Radio Module	9.2 mm x 8.4 mm x 1.35 mm
WLS1271L	2.412-2.485 GHz	b/g/n compliant	4.0+EDR, Power Class 1.5+BLE	802.11b/g/n + Bluetooth Combo Short-Range Radio Module	9.2 mm x 8.4 mm x 1.35 mm
WLS1273L	2.412 to 2.485 GHz 4.920 to 5.824 GHz	a/b/g/n compliant	4.0+EDR, Power Class 1.5+BLE	802.11a/b/g/n + Bluetooth Combo Short-Range Radio Module	11.4 mm x 9.4 mm x 1.4 mm

IEEE 802.11 SPECIFICATION HIGHLIGHTS

IEEE 802.11	WLS1270	WLS1271L	WLS1273L
	b/g/n compliant	b/g/n compliant	a/b/g/n compliant
Operating Frequency Range	2.412 to 2.485 GHz	2.412 to 2.485 GHz	2.412 to 2.485 GHz 4.920 to 5.824 GHz
Power Output	Up to 16 dBm	Up to 18 dBm	Up to 18 dBm
Supply Current	TX -180 mA / RX -100 mA	TX -250 mA typ / RX -100 mA	TX -265 mA typ / RX -100 mA
Size	9.2 mm x 8.4 mm x 1.35 mm	9.2 mm x 8.4 mm x 1.35 mm	11.4 mm x 9.4 mm x 1.4 mm
Microprocessor	Embedded ARM Microprocessor	Embedded ARM Microprocessor	Embedded ARM Microprocessor
Operating Temperature Range	-40 °C to +85 °C	-40 °C to +85 °C	-40 °C to +85 °C
Other	Supports SDIO host interface for WLAN	Supports SDIO host interface for WLAN	Supports SDIO host interface for WLAN

BLUETOOTH SPECIFICATION HIGHLIGHTS



Bluetooth	WLS1271L	WLS1273L
	4.0 plus EDR, Power Class 1.5 +BLE	4.0 plus EDR, Power Class 1.5 +BLE
Operating Frequency Range	2.4000 to 2.4835 GHz	2.4000 to 2.4835 GHz
Power Output	Up to 8 dBm	Up to 8 dBm
Supply Current	35 mA	35 mA
Data Rate	Up to 3 Mb/s	Up to 3 Mb/s



WI-FI & WI-FI + BLUETOOTH COMBINATION SHORT-RANGE RADIO MODULES

Evaluation Kits and Samples

**Fast-track Your Design...
Order Your Evaluation Kits and Samples Today!**

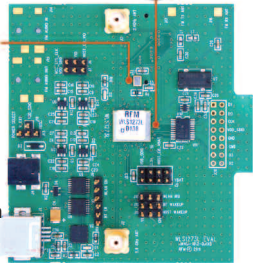
Evaluation Kits	
RFM Part	<ul style="list-style-type: none"> • Test Wi-Fi RF performance • Test Bluetooth RF performance • SDIO interface • Hi Speed USB interface • Host Interface
DR-WLS1270-EV	 <p>DR-WLS1270-EV DR-WLS1271L-EV</p> <p>DR-WLS1273L-EV</p>
DR-WLS1271L-EV	
DR-WLS1273L-EV	
	<p>Evaluation Kit Contains:</p> <ul style="list-style-type: none"> • (1) Evaluation Board • CD with GUI • USB Cable • (1) Antenna WLS1270/71L Kits • (2) Antennas WLS1273L Kit
	<p>WLS1273L Wi-Fi+ Bluetooth Combo Module Smaller than a Dime </p> <p>RFM TCXO XTC7012 Placed on Eval Board</p>  <p>WLS1273L Module Installed on DR-WLS1273L-EV Evaluation Board</p>

Small Quantities Available for Purchase	
RFM Part	<p>Small quantities are available for design support. For customer convenience, one TCXO XTC7012 sample is included with each WLS sample purchased at no additional charge. Contact your local RFM authorized sales representative or distributor for more information. Go to the following URL to locate a sales rep or distributor nearest you. http://www.rfm.com/contact_php/map.php</p>
WLS1270-S	
WLS1271L-S	
WLS1273L-S	

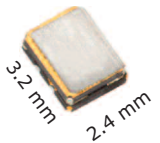
High Performance TCXO for Healthcare and High Speed Data Applications				
RFM Part	Frequency	Tol / Spec	Case (mm)	Packaging
XTC7012	38.4 MHz	±5.0 ppm, -40 °C to +85 °C	3.2 mm x 2.5 mm	Surface Mount Packages Shipped in either 7" tape and reel quantity of 1,000 or 13" in quantity of 3,000
<p>The RFM XTC7012 TCXO was designed specifically for the WLS-Series modules, particularly for the WLS1273L module as it is 802.11a and 11n compliant. The XTC7012 will provide frequency stability to the WLS1273L for years and years of healthcare and high speed data applications. See the complete portfolio of RFM Crystal and SAW RF Components that includes a broad line of high-performance crystal frequency control products used in most wireless and digital applications (resonators, filters, oscillators, TXCO, VCXO, OCXO, and VCTCXO).</p>				
				

Design Support			
DRIVER SUPPORT			
<p>The majority of applications today are being developed in a combination with either Linux or Android operating systems due to their fast throughput capabilities in Wi-Fi / Bluetooth applications. RFM has available for designers Linux and Android drivers for OMAP processors, or driver source code is available that can be modified for other ARM Cortex A-Series processors.</p>			
 <p>Quick Time-to-Market</p>	Platform	OS	
	OMAP™3 / OMAP™4 / AM18x / AM37x	Linux 2.6	Mac Firmware / BT Scripts
	OMAP™3 / OMAP™4 / AM18x / AM37x	Android	Mac Firmware / BT Scripts
	OMAP™3 / OMAP™4 / AM18x / AM37x	WinCE 6	Mac Firmware / BT Scripts
<ul style="list-style-type: none"> • The above Platforms and OS are the quickest time to market and require the least amount of Driver support. • Only hardware design is needed for both Wi-Fi and Bluetooth. • Other platforms or OS's require driver design or slight modification. 			

REFERENCE DESIGNS

RFM's reference designs for SDIO and host interface are available with RFM evaluation kits. These are valuable tools designers may use to speed up development cycles.

SALES & SUPPORT

Hundreds of individuals are available to serve customers' needs via the worldwide network of RFM authorized sales representatives, distributors, and stocking representatives / distributors. To locate a sales rep or distributor nearest you, go to the following URL http://www.rfm.com/contact_php/map.php

WLS-Series Wi-Fi and Wi-Fi + Bluetooth Combination Short-Range Radios: The WLS Series modules are designed to fit into small spaces, with minimal external circuitry required to complete a radio design. Software is available for Linux and Android operating systems. For high-performance frequency control, RFM recommends its XTC7012 Temperature-Compensated Crystal Oscillator (operating at 38.4 MHz) for all WLS modules.

WLS1270 FEATURES

- IEEE 802.11b/g and 11n compliant
- IEEE 802.11d,e,h,i,k,r,s compliant

WLS1270 WLAN Highlights

Data Rates:

802.11n: 65, 58.5, 52, 39, 26, 19.5, 13, 6.5 Mbps
 802.11g: 54, 48, 36, 24, 18,12, 9, 6 Mbps
 802.11b: 11,5.5, 2, 1 Mbps

Operating Frequency Range: 2.412 to 2.484 GHz

Output Power: up to 16 dBm

Supply Current: Transmit - 180 mA / Receive - 100 mA

Operating Temperature Range: -40 to 85 °C

Relative Humidity: 5 to 95%, non-condensing

- Chipset: Texas Instruments WL1270
- Size: 9.2 x 8.4 x 1.35 mm maximum
- Embedded ARM microprocessor
- Supports SDIO host interface for WLAN
- Lead-free module construction

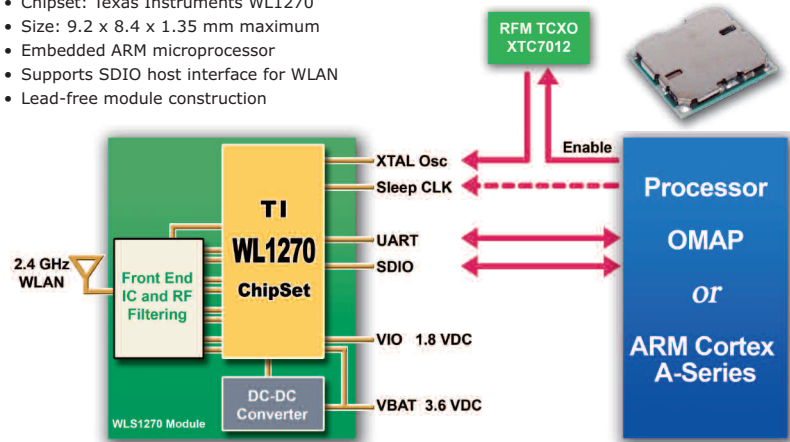

WLS1271L FEATURES

- IEEE 802.11b/g and 11n compliant
- IEEE 802.11d,e,h,i,k,r,s compliant
- Bluetooth Version 4.0 plus EDR, Power Class 1.5 +BLE
- The firmware running on the microprocessor includes the lower layers of the Bluetooth Protocol up to HCI available (Link Controller, Link Manager, HCI and HCI Transport Layer)

WLS1271L WLAN Highlights

Data Rates:

802.11n: 65, 58.5, 52, 39, 26, 19.5, 13, 6.5 Mbps
 802.11g: 54, 48, 36, 24, 18,12, 9, 6 Mbps
 802.11b: 11,5.5, 2, 1 Mbps

Operating Frequency Range: 2.412 to 2.484 GHz

Output Power: up to 18 dBm

Supply Current: Transmit -250 mA typ / Receive - 100 mA

Operating Temperature Range: -40 to 85 °C

Relative Humidity: 5 to 95%, non-condensing

WLS1271L Bluetooth Highlights

Data Rates: up to 3 Mb/s

Operating Frequency Range: 2.4000 to 2.4835 GHz

Output Power: up to 8 dBm

Supply Current: 35 mA typical (DH1)

- Chipset: Texas Instruments WL1271L
- Size: 9.2 x 8.4 x 1.35 mm maximum
- Embedded ARM microprocessor
- Supports SDIO host interface for WLAN
- Lead-free module construction
- Supports H4 or H5 (UART) host interfaces and PCM audio interfaces for Bluetooth

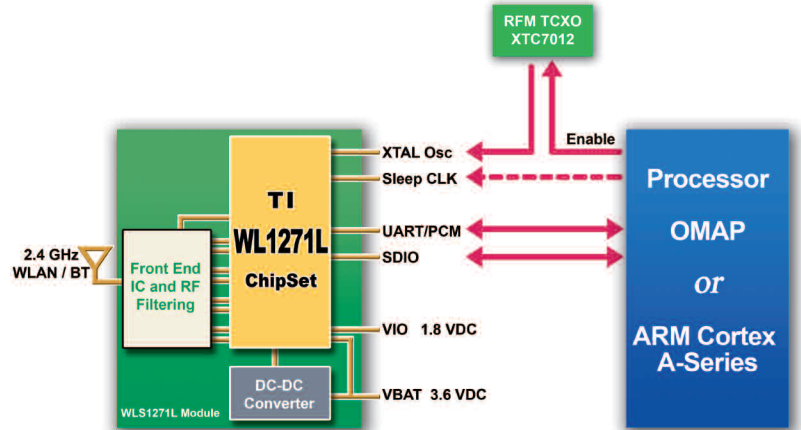

WLS1273L FEATURES

- IEEE 802.11a/b/g and 11n compliant
- IEEE 802.11d,e,h,i,k,r,s compliant
- Bluetooth Version 4.0 plus EDR, Power Class 1.5 +BLE
- The firmware running on the microprocessor includes the lower layers of the Bluetooth Protocol up to HCI available (Link Controller, Link Manager, HCI and HCI Transport Layer)

WLS1273L WLAN Highlights

Data Rates:

802.11a: 6, 9, 12, 24, 36, 48, 54 Mbps
 802.11n: 65, 58.5, 52, 39, 26, 19.5, 13, 6.5 Mbps
 802.11g: 54, 48, 36, 24, 18,12, 9, 6 Mbps
 802.11b: 11,5.5, 2, 1 Mbps

Operating Frequency Range: 2.412 to 2.484 GHz and 4.920 to 5.825 GHz

Output Power: up to 18 dBm

Supply Current: Transmit -265 mA typ / Receive - 100 mA

Operating Temperature Range: -40 to 85 °C

Relative Humidity: 5 to 95%, non-condensing

WLS1273L Bluetooth Highlights

Data Rates: up to 3 Mb/s

Operating Frequency Range: 2.4000 to 2.4835 GHz

Output Power: up to 8 dBm

Supply Current: 35 mA typical (DH1)

- Chipset: Texas Instruments WL1273L
- Size: 11.2 x 9.4 x 1.35 mm maximum
- Embedded ARM microprocessor
- Supports SDIO host interface for WLAN
- Lead-free module construction
- Supports H4 or H5 (UART) host interfaces and PCM audio interfaces for Bluetooth

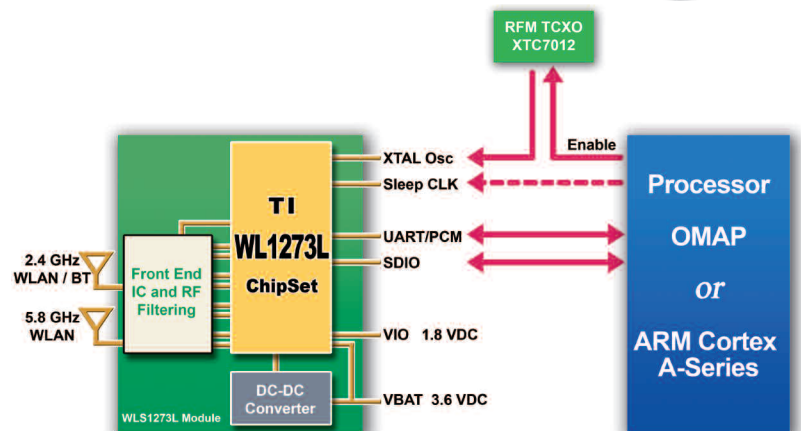

TRADEMARKS: RF Monolithics, Wireless is...RFM, and the stylized RFM logo are registered trademarks of RFM. All other trademarks such as Wi-Fi and Bluetooth are the property of their respective owners.

INFORMATION SUBJECT TO CHANGE: The specifications and availability of the components described in this publication are subject to change without notice. Every effort has been made to ensure the accuracy of this publication. However, RFM does not assume responsibility for inaccuracies or changes.